



EZ50

Tracked Zero Tail excavator

The compact and powerful zero-tail excavator

Full speed ahead: The EZ50 mini-excavator offers excellent lifting and digging power as well as quick work cycles. Using the newest technologies, the emissions of the mini-excavator were reduced and, at the same time, the efficiency increased. For example, the powerful engine in the EZ50 meets the stage 5 exhaust emission standards. In terms of operator-friendliness, the excavator is impressive. The intuitive operating concept and excellent view of the work area contribute to the easy and comfortable operation of the machine. The EZ50 is also a zero-tail excavator and is well suited for working in narrow spaces.

Highlights

- Flexible cylinder rod protection
- 3-point kinematics
- Active Working Signal (AWS)
- Load Sensing Flow Sharing
- Zero tail

Technical Data

Hydraulic

operating pressure	245,0 bar
hydraulikpump	Axialkolbenpumpe
flow rate	126,0 l/min
flow rate max.	126,0 l/min

Mechanical - Output Details

Travel speed	4,4 km/h
--------------	----------

Mechanical Details

Length	6.050,0 mm
Width	1.960,0 mm
Height	2.667,0 mm
Weight	4.617,00 kg
Aggr. pwr time limited 1~(LTP)	4.847,0 - 5.855,0 kg
Digging depth (max.)	3.667,0 mm

Engine

Cooling	water-cooling
Engine type	Diesel engine
Cylinder	3,0
Cylinder capacity	1.662,0 cm3
Effective power	32,5 KW
Nominal Engine speed	2.000,0 1/min
Exhaust-gas limit	EU Stage V
Battery capacity (nom. value)	77,0 Ah
Manufacturer	Perkins
Engine designation	403J-E17T

Environment Data

Sound power LWA, guaranteed	97,0 dB(A)
-----------------------------	------------

Shipping and Storage

Shipping weight	4.617,0 kg
-----------------	------------

Dimensions

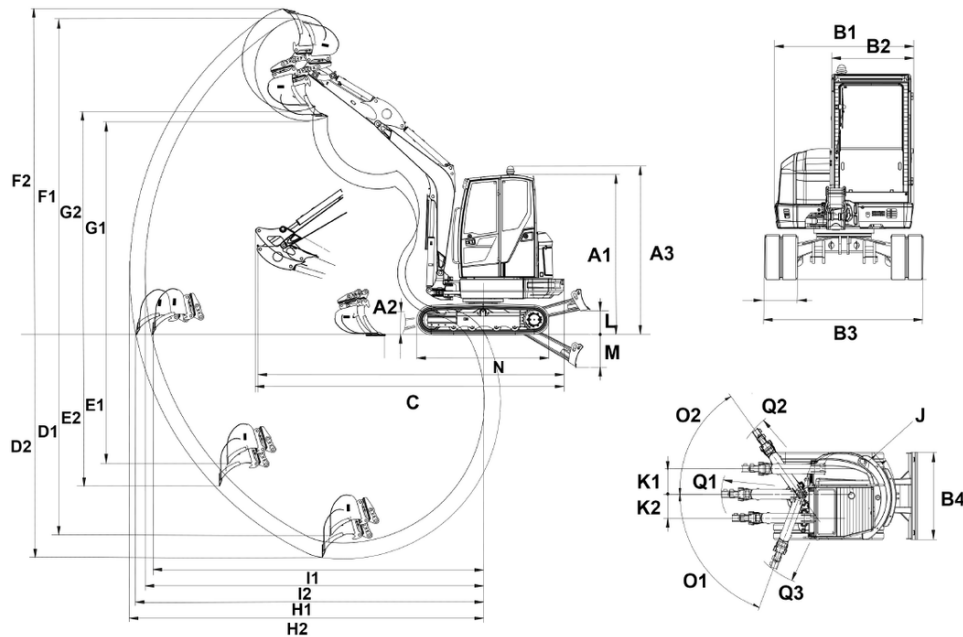

A1	Height with cab	2,555 mm
A3	Total height with rotating beacon	2,667 mm
B1	Width of upper carriage	1,724 mm
B2	Width of cab	980 mm
B3	Width travel gear	1,960 mm
B4	Width of dozer blade	1,960 mm
C	Transport length short shovel arm	5,467 mm
	Transport length long shovel arm	5,482 mm
D1	Digging depth max., short shovel arm	3,467 mm
D2	Digging depth max., long shovel arm	3,667 mm
E1	Piercing depth max., short shovel arm	2,085 mm
E2	Piercing depth max., long shovel arm	2,262 mm
F1	Piercing height max., short shovel arm	5,470 mm
F2	Piercing height max., long shovel arm	5,599 mm
G1	Dumping height max., short shovel arm	3,655 mm
G2	Dumping height max., long shovel arm	3,784 mm
H1	Digging radius max., short shovel arm	5,916 mm
H2	Digging radius max., long shovel arm	6,150 mm
I1	Max. reach at ground level (short shovel arm)	5,794 mm
I2	Max. reach at ground level (long shovel arm)	5,988 mm
J	Tail swing radius	1,047 mm
	Tail swing radius with tail weight	1,152 mm
K1	Boom offset max. (to center of bucket right side)	764 mm
K2	Boom offset max. (to center of bucket left side)	770 mm
L	Stacking height max. (dozer blade above surface)	410 mm
M	Digging depth max. (dozer blade below surface)	443 mm
N	Length travel drive	2,508 mm
O1	Max. swivel angle (arm system to the left)	70 °
O2	Max. swivel angle (arm system to the right)	55 °
Q1	Boom swing radius center	2,505 mm
Q2	Boom swing radius right	2,329 mm
Q3	Boom swing radius left	2,064 mm
	Distance bucket dozer blade, short shovel arm	429 mm
	Distance bucket dozer blade, long shovel arm	333 mm