



DV45

Dual View Wheel Dumper

The next level of the Dual View dumper

The cabin can be rotated when driving at the press of a button on the right joystick. The optional Multi View mode therefore provides the ability to work with a cabin turned to the side in order to have an overview to the side of the machine and the skip. At the press of a button, the cabin is automatically rotated, whereby the operator can concentrate on the primary work. Additional safety features round off the optimal overall package with a maximum payload of {4,200kg} {9,259lb}. The DV45 is simultaneously characterized with the familiar high level of comfort features, the very good stability, and the hydrostatic 4-wheel drive with ECO mode.

Highlights

- Rotating cab
- Multi View Mode
- Automatic skip return
- Inclination monitoring
- Active Sense Control

Technical Data

Hydraulic

Operating pressure	240.0 bar
Tank capacity	53.0 l

Mechanical - Output Details

Travel speed	25.0 km/h
--------------	-----------

Mechanical Details

Length	4,400.0 mm
Width	1,780.0 mm
Height	3,274.0 mm
Weight	4,114.00 kg
Weight cabin	4,640.0 kg
Payload	4,200.0 kg
skip	Swivel skip
Skip capacity levelled	1,810.0 l
Skip capacity heaped	2,400.0 l
Skip capacity waterlevel	1,350.0 l
Pendulum angle	15.0 °

Engine

Cooling	Water-cooling
Motor type	Diesel engine

Cylinder	3.0
Cylinder capacity	1,663.0 cm3
Inclined position max.	20.0 °
Fuel type	Diesel EN 590
Tank capacity	53.0 l
Effective power	36.0 KW
Nominal Engine speed	2,300.0 1/min
Exhaust-gas limit	EU Stage V
Starter battery Voltage	12.0 V
Manufacturer	Perkins
Engine designation	403J-E17T

Environment Data

Sound power LWA, guaranteed	98.0 dB(A)
Sound power LWA (Standard)	ISO 6395

Operating Fluids

Fuel specification	Diesel EN 590
Fuel Tank capacity	55.0 l
Fuel Tank Volume	46.0 l

Chassis

Turning radius	4,465.0 mm
----------------	------------

Articulation angle	36.0 °
drive unit	Swash plate motor
hydraulikpump	Gear pump
Operating pressure	240.0 bar

tires 11.5/80-15,3 - 14PR

■ Shipping and Storage

Shipping weight	2,991.0 kg
-----------------	------------

Dimensions

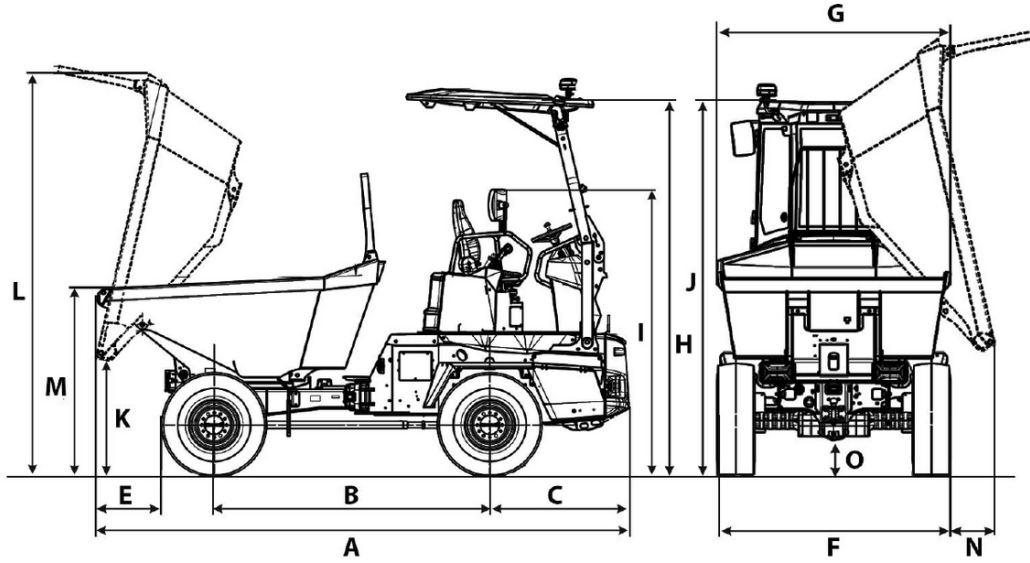

A	Total length	4,400 mm
B	Wheel base	2,280 mm
C	Rear overhang	1,155 mm
E	Dumping width	503 mm
F	Width of vehicle	1,780 mm
G	Width of skip	1,775 mm
H	Height ROPS	3,060 mm
I	Height of ROPS tilted	2,363 mm
J	Height with cab	2,841 mm
K	Dumping height max.	945 mm
L	Skip height tilted	3,317 mm
M	Skip height	1,634 mm
N	Dumping width lateral	335 mm